



TIG200

Top Features

- ❖ High current range of 180 amps highly fit for the precision welding
- ❖ Multi-function: Continuous and Spot MIG/MAG process
- ❖ Convenient LED operational interface. Automatically matching welding parameter
- ❖ Overheat, over-current and over-voltage detection, anti-shock and anti-sticking functions
- ❖ IP21S classification to ensure reliability in harsh and demanding environmental conditions

<i>Technical</i>	<i>Parameters</i>	<i>Technical</i>	<i>Parameters</i>
Input Power	220V(±15%)/1Ph/50HZ/60HZ	Efficiency (%)	≥80
Rated input current (A)	24	Insulation grade	F
Rated Output Current /Voltage/Duty Cycle	8-180A/17.2V/40%	Housing protection grade	IP21S
No load loss (W)	40	Net Weight (kg)	6.25
Power factor	≥0.7	Dimensions H×W×D (mm)	378 x 159 x 298

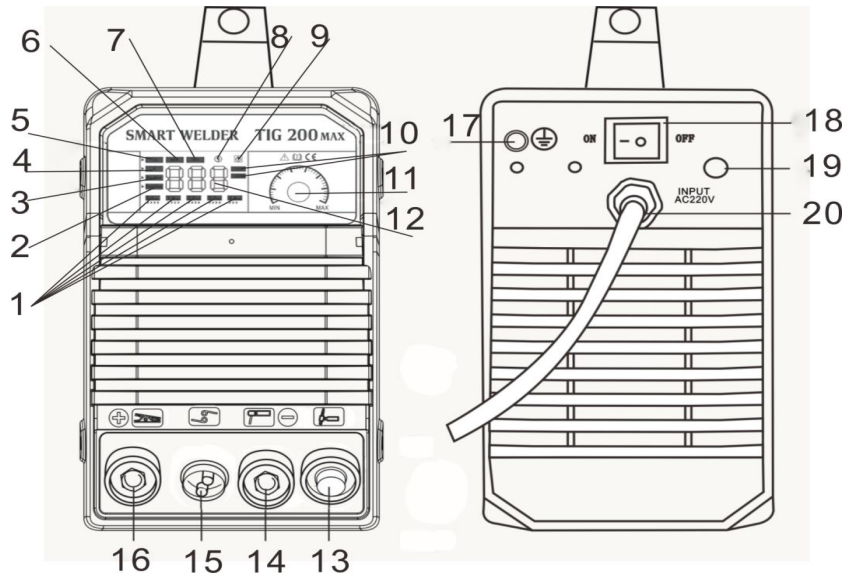

<i>Function description</i>			
1	Plate thickness indicator	11	①current adjustment knob ②Press to switch functions
2	Post Flow	12	Digital ammeter
3	Pre Flow	13	Argon welding torch interface
4	Current adjustment indicator	14	Negative output terminal
5	TIG welding light	15	The welder controls the socket
6	Manual welding indicator light	16	Positive output terminal
7	Spot	17	Earth connecting screw
8	protection lamp	18	Power switch
9	Power lamp	19	Air intake
10	Input voltage indicator light	20	Input power line

ACCESSORY DRAWING

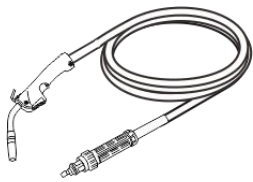

MIG Torch

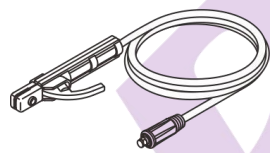

Electrode holder with cable



Earth clamp with cable

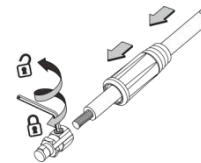

Connector assembly way



Internal hexagonal wrench

INSTALLATION INSTRUCTION

Long connecting cable can affect the ARC start character and stability of welding performance, so please use the recommended cable length, and in order to reducing the voltage down, please use the large cable face:

1. Please use at least 6mm² cable to connect the welder to the earth.
2. Please make sure the power supply is right match for the welder and install the torch, earth clamp according to the right instruction;
 - 1) Using the MMA function, please connect the earth clamp and electrode holder according to the nature of electrode, and tighten the connector.
 - 2) Using the TIG function, please following the installation instruction to install the the torch and tighten it.
3. For the earth clamp, please let the connector connect to "+", and the other side connect to the workpiece.
4. Before using the welder, please check the cable is right connected as the following picture and tighten them.
5. Please pay attention to polarity, since there are two connecting method for MMA process. ① positive pole connecting method, earth clamp connect to "-" and electrode holder connect to "+"; ② negative pole connecting method, earth clamp connect of "+" and electrode holder connect to "-".

Please noted that which connecting way would be used is up to the workpiece processing requirement, if using the wrong connecting way, it will occur some phenomenon.

