



TIG200SJ

Top Features

- ❖ High current range of 200 amps highly fits for the thin plates welding
- ❖ MMA welding current 170 A provides the ability to weld 3.2 electrode
- ❖ Adjustable Spot TIG time and frequency
- ❖ Convenient digital operational interface
- ❖ Portable, energy saving and high efficiency
- ❖ Overheat, over-current and over-voltage detection, anti-shock and anti-sticking functions
- ❖ IP21S classification to ensure reliability in harsh and demanding environmental conditions

<i>Technical</i>	<i>Parameters</i>	<i>Technical</i>	<i>Parameters</i>
Input Power	220V(±15%)/1Ph/50HZ/60HZ	Efficiency (%)	80
Rated input current (A)	15.5	Power factor	0.73
Rated Output Current /Voltage/Duty Cycle	8-200A/17.6V/60%	Insulation grade	F
MMA current (A)	10-170	Housing protection grade	IP21S
No-load voltage (V)	56	Net Weight (kg)	6.25
No-load loss (W)	40	Dimensions H×W×D (mm)	378 x 159 x 298

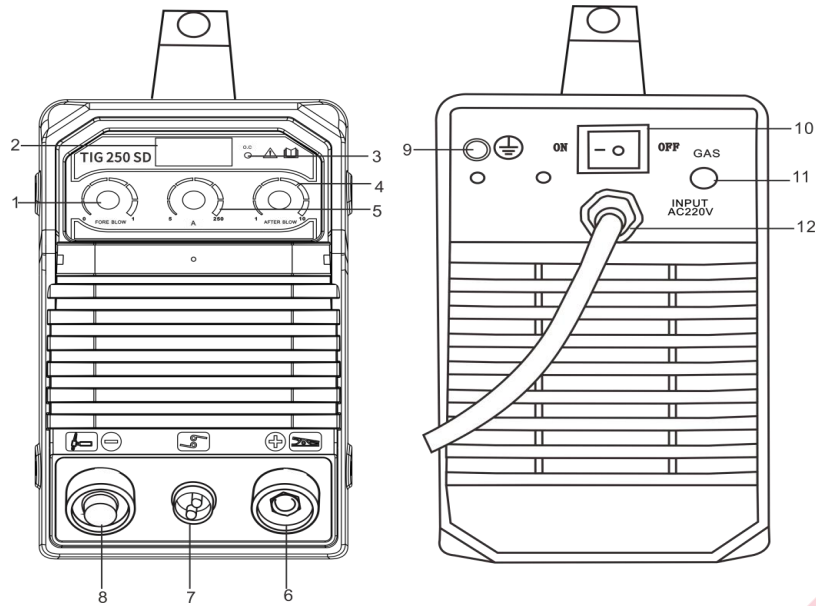

<i>Function description</i>			
1	Front air conditioning potentiometer	7	Welding gun control socket
2	Digital ammeter	8	Argon welding torch interface
3	protection lamp	9	Earth connecting screw
4	The rear air conditioning potentiometer	10	Power switch
5	Welding current adjustment	11	Air intake
6	Positive output terminal	12	Input power line

ACCESSORY DRAWING

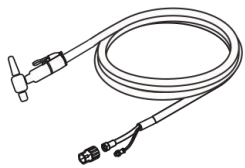

TIG Torch

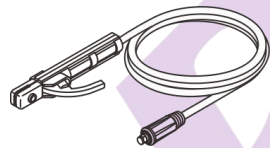

Electrode holder with cable

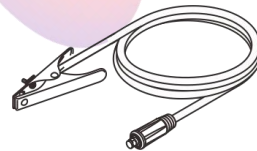

Earth clamp with cable

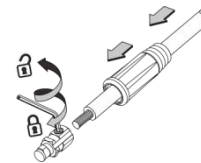

Connector assembly way



Internal hexagonal wrench

INSTALLATION INSTRUCTION

Long connecting cable can affect the ARC start character and stability of welding performance, so please use the recommended cable length, and in order to reducing the voltage down, please use the large cable face:

1. Please use at least 6mm² cable to connect the welder to the earth.
2. Please make sure the power supply is right match for the welder and install the torch, earth clamp according to the right instruction;
 - 1) Using the MMA function, please connect the earth clamp and electrode holder according to the nature of electrode, and tighten the connector.
 - 2) Using the TIG function, please following the installation instruction to install the the torch and tighten it.
3. For the earth clamp, please let the connector connect to "+", and the other side connect to the workpiece.
4. Before using the welder, please check the cable is right connected as the following picture and tighten them.
5. Please pay attention to polarity, since there are two connecting method for MMA process. ① positive pole connecting method, earth clamp connect to "-" and electrode holder connect to "+"; ② negative pole connecting method, earth clamp connect of "+" and electrode holder connect to "-".

Please noted that which connecting way would be used is up to the workpiece processing requirement, if using the wrong connecting way, it will occur some phenomenon.

