



CUT160CI

Top Features

- ❖ Current range of 160 amps provides the ability to cut up to 0.5-55 mm plates
- ❖ High frequency and voltage arc ignition
- ❖ Small body, mighty performance, long time quality cutting
- ❖ Convenient operational interface with digital meter
- ❖ Overheat, over-current and over-voltage detection, anti-shock and anti-sticking functions
- ❖ Built to IP21 classification to ensure reliability in harsh and demanding environmental conditions

<i>Technical</i>	<i>Parameters</i>	<i>Technical</i>	<i>Parameters</i>
Input Power	380V(±10%)/3Ph/50HZ/60HZ	Power factor	0.93
Rated input current (A)	44	Insulation grade	F
No-load voltage (V)	320	ARC starting manner	No contact
Rated Output Current /Voltage/Duty Cycle	22-160A/144V/60%	Housing protection grade	IP21
No-load loss (W)	80	Net Weight (Kg)	60
Efficiency (%)	85	Dimensions H×W×D (mm)	670 x 337 x 617
Pressure of air (KG)	4-6		

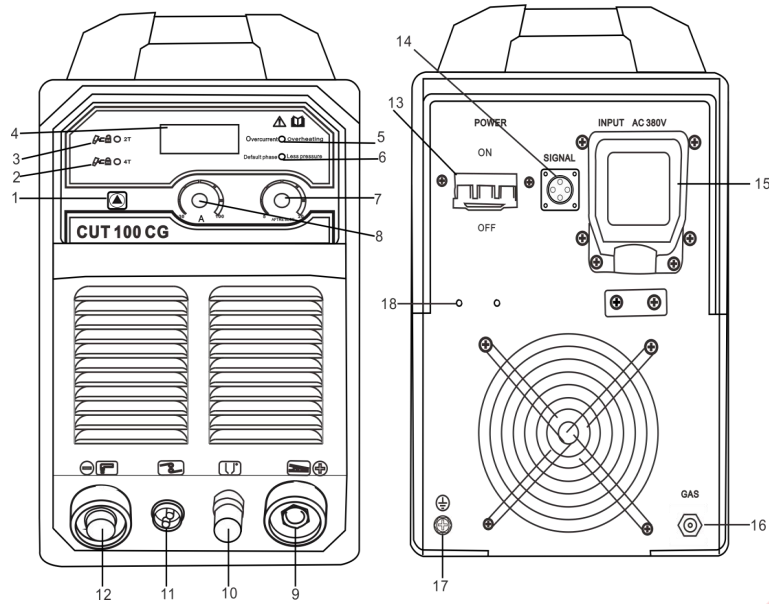

<i>Function description</i>			
1	2T / 4T function switch button	10	Dimensional arc terminal block
2	4T status indicator	11	Welding gun control socket
3	2T status indicator	12	Gas and electricity socket
4	Digital ammeter	13	Power switch
5	O.C indicator	14	CNC signal interface socket Arc starting signal Arc voltage signal Arc voltage signal positive
6	Phase lack / low pressure indicator	15	Input power line terminal block
7	Post air knob	16	Air intake
8	Current knob	17	Earth connecting screw
9	Positive output	18	Air pressure relief valve bracket fixing hole

ACCESSORY DRAWING

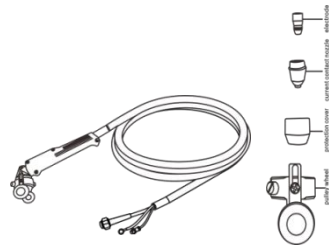

Cutting torch

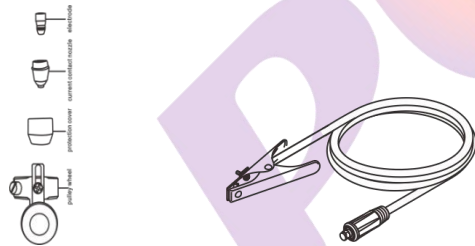

Earth clamp with cable

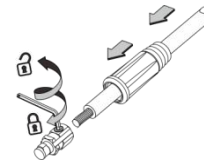

Connector assembly way



Internal hexagonal wrench

INSTALLATION INSTRUCTION

When using a longer cable to reduce the voltage drop, it is recommended to use a larger cross-section cable, If connecting cable too long maybe will seriously impact arc performance and other performance

- 1、 Make sure the cutting power supply vents are not covered and blocked, so as to avoid cooling system failure.
- 2、 Connect the chassis with ground with conductor which cross sectional area not less than 6mm^2 , The method is to connect the grounding device from the protective grounding screw on the back of the welder, or confirm that the ground of the power outlet has been reliably grounded separately, the two methods can be used together to ensure safety.
- 3、 Use a trachea to connect the gas inlet and compressed air source behind the cutter, use a hose clamp or other method to tie the interface, So as to avoid leakage and to ensure that the gas source can provide the appropriate pressure、 Sufficient flow, and is dry, if your existing gas source can not meet the above requirements, you should consider the use of a separate enough power of the air compressor and gas decompression filter to ensure the normal work of the machine.
- 4、 Install the gauges of the cutting guns on the corresponding interface of the cutter panel, And fasten with a wrench clockwise, The air plug and the dimension arc on the cutting gun are connected to the corresponding interface of the cutter panel respectively, Tighten the interface screw Insert the quick plug of the workpiece cable into the quick socket of the cutter panel and tighten it clockwise, the other end of the ground clamp clamp the workpiece.
- 5、 Connect the power cord to the corresponding voltage level distribution box according to the input voltage level of the cutting machine,do not choose the wrong voltage, While ensuring that the supply voltage error within the allowable range.
- 6、 Connecting the corresponding cable according to the map, you can proceed to the next step.

