



MIG180CI

Top Features

- ❖ High current range of 160 amps provides the ability to weld over 0.8 mm plate
- ❖ MMA function ensures the power to weld 3.2 electrodes
- ❖ MCU synergic control technology, getting you free from parameter adjusting trouble
- ❖ Multi-function: gasless flux core, gas solid wire and MMA process
- ❖ Convenient operational interface with digital meter. Automatically matching welding parameters
- ❖ Perfect match for 1.0mm flux core wire, 0.8mm solid wire and 3.2mm electrodes
- ❖ Overheat, over-current and over-voltage detection, anti-shock and anti-sticking functions
- ❖ Built to IP21S classification to ensure reliability in harsh and demanding environmental conditions

<i>Technical</i>	<i>Parameters</i>	<i>Technical</i>	<i>Parameters</i>
Input Power	220V(±10%)/1Ph/50HZ/60HZ	Wire diameter (mm)	0.8/1.0
Rated input current (A)	33	Insulation grade	F
Rated Output Current /Voltage/Duty Cycle	30-160A/25V/30%	Housing protection grade	IP21S
Power factor	≥0.73	Applicable thickness (mm)	Over 0.8
Efficiency (%)	≥80	Output cable (mm ²)	Over 12
Wire feed speed (m / min)	2-13	Net Weight (kg)	5.5
Post flow time(S)	1.0±0.5	Dimensions H×W×D (mm)	344 x 159 x 2677

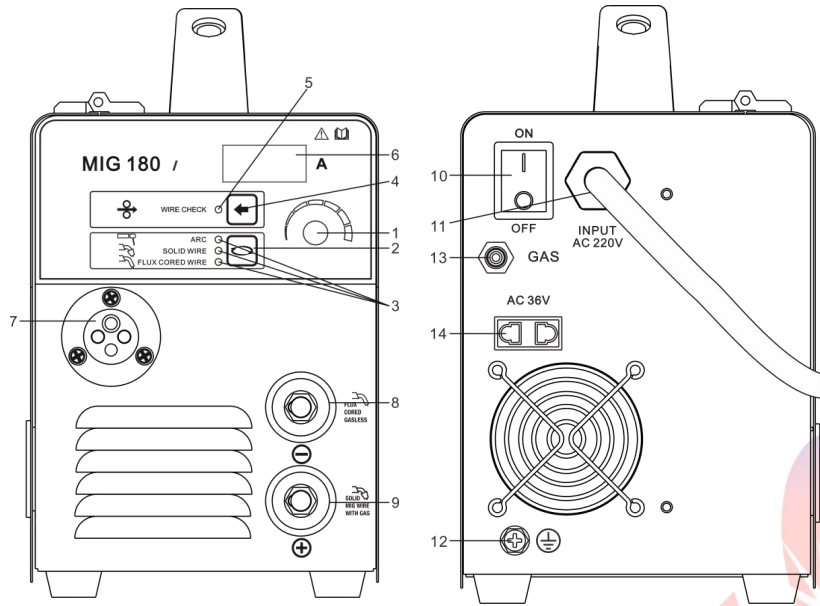

<i>Function description</i>			
1	Current adjustment knob	8	Negative output
2	ARC/Solid wire/Flux-core switch button	9	Positive output
3	ARC/Solid wire/Flux-core indicator	10	Power switch
4	Wire checking function button	11	Input power line
5	Wire checking indicator	12	Grounding bolt
6	Ammeter	13	Air intake
7	Gas and electricity integrated socket	14	AC 36V Gas meter supply

ACCESSORY DRAWING

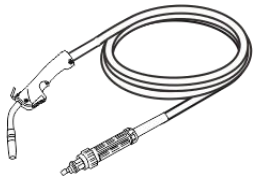

MIG Torch

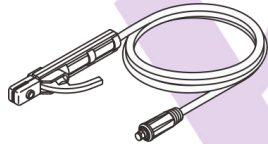

Electrode holder with cable

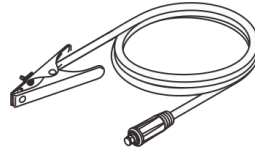

Earth clamp with cable

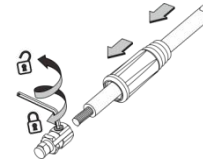

Connector assembly way



Internal hexagonal wrench

INSTALLATION INSTRUCTION

If the connecting cable is too long, it will have a great influence on the arcing performance as well as the stability of the welding performance. Therefore, please use the recommended length. If you want to reduce the voltage drop, please use a cable with a larger cross section.

- 1) The gas cylinder equipped with the carbon dioxide gas pressure reducing flow meter is closely connected with the gas inlet of the carbon dioxide inlet at the back of the machine.
- 2) Plug the ground wire quick plug into the corresponding quick socket on the front panel.
- 3) The wire spool equipped with the welding wire is mounted on the frame shaft of the wire feeder, and the hole position of the wire wire plate is aligned with the fixing bolt on the frame shaft.
- 4) Depending on the diameter of the wire used, choose a different wire feed slot.
- 5) Loosen the nut of the pressure roller, feed the welding wire into the wire feeder groove through the wire guide tube, adjust the pressure wire to press the welding wire to ensure that the welding wire does not slide, but the pressure should not be too large, to prevent the wire from being deformed and affecting the wire feeding.
- 6) The wire spool should be rotated clockwise to release the wire. In order to prevent the wire from loosening, the new wire disk head is often placed in the fixing hole on the side of the wire disk. In order to prevent the bent wire from being stuck during normal use, cut off this part of the wire.
- 7) The torch is inserted into the output socket of the front panel and tightened, and the wire is inserted into the gun body. Ground the cables with section area no less than 6mm² to the housing, the way is connecting screw in the back of the power source to ground device;

