

INVERTER MMA/ARC SMART WELDER MAX SERIES











USER`S MANUAL



**PLEASE CAREFULLY READ THIS MANUAL BEFORE ASSEMBLY,
USEING OR MAINTAINANCE**

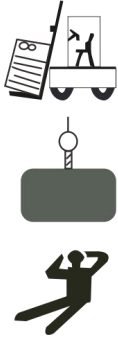

WARNING When the DC inverter welder works with AC welder, please don't let the output cable of two different machine connected together in case of welder damage

 DANGER	<p>Once you touch the electric parts will result in electric shock</p> <ul style="list-style-type: none"> • Don't touch the electric parts.
	<ul style="list-style-type: none"> • Make sure the welder connect to earth before using. • Off power supply while assembly and maintenance. • Don't use the welder while opening the case. • Please use the good insulating gloves.
 CAUTION	<p>ARC、Spatter and slag may burn eyes and skin, abnormal noise may hurt hearing</p>
	<ul style="list-style-type: none"> • Please use the welding mask to protect your face and eye • Please use the welding clothes to protect your body • Please use hearing protecting tool when it is noising
 DANGER	<p>Using welder in a narrow place or higher have the potential to cause electric shocks, stinging lead to falls and other accidents.</p>
	<ul style="list-style-type: none"> • Please use the VRD device or build-in VRD welder in the following location • 2m or higher location with risk of falling, workers who may be exposed to bars and other places of grounding electrical conductivity. • Please check the VRD device per the safety rule while operating
 CAUTION	<p>The dust, smoke or gas caused by welding are bad for health</p>
	<ul style="list-style-type: none"> • Please use local exhaust ventilation equipment and respiratory protective equipment. • When operating in narrow places, please check and accept monitoring of adequate ventilation, wearing of respiratory protective equipment • Please don't use the welder in the degreasing, cleaning and spraying area
 CAUTION	<p>It may result in fire, blasting or other accident during welding</p>
	<ul style="list-style-type: none"> • Please don't place any Combustible and flammable gases in the welding location. • Please don't weld any airtight container, like oil tank or tube or others • Please equip with fire apparatus in welding location.
 CAUTION	<p>Lifting Device:</p> <p>The standard package for this welder is carton or wooden box without any connector for lifting device, so when the welder arrive, please use the fork lift truck to move the machine and then open it.</p>
	<ul style="list-style-type: none"> • When the welder equipped with rings for lifting, you can use the ring to transport the machine, but please notice that don't use roller to move the welder since it may damage the welder • Please make sure all accessories have been removed when lifting • When the welder is being lifted, please make sure there is nobody below the welder and there is someone to mention the passengers. • Please don't use the crane to move the welder quickly. • Please install the welder in accordance with the assembly direction.

WARNING Please make the generator's power at least 2 times than the welder's rated power when using generators as power supply

CONTENTS

CONTENTS	1
1、 MACHINE DESCRIPTION	2
2、 TECHNICAL PARAMETERS TABLE	3
3、 PANEL FUNCTION INSTRUCTION	4
4、 ACCESSORY DRAWING	5
5、 INSTALLATION INSTRUCTION	5
6、 OPERATING INSTRUCTIONS	6
7、 PRECAUTIONS	7
8、 MAINTENANCE,AFTER-SALES	8
9、 TROUBLESHOOTING AND FAULT FINDING	8

1. MACHINE DESCRIPTION

1) INVERTER MMA/ARC SMART WELDER MAX SERIES FEATURES

ARC160MAX、ARC200MAX、ARC230MAX、ARC260MAX、ARC330MAX inverter MMA/ARC smart welder max series are our company's own R & D design , which has the following advantages:

- ① Strong ability against the power fluctuation, it can work normally under the fluctuation of $\pm 15\%$;
- ② Fashionable appearance, LED display ,small size, light weight and easy to move;
- ③ Using the three-proofed structure against the dust,moisture and corrosion, very considerable protection for all the electronic components;
- ④ This series of manual arc welding machine have been used the current-mode PWM pulse width adjustment technology,IGBT inverter technology and high-power fast recovery diode application technology, to ensure the product stability;
- ⑤ With under-voltage, overheating, over current, lack of phase protection, to ensure product reliability;
- ⑥ Stable output performance, real-time monitoring of the welding output power, the effective management of the output current to ensure welding welding reliability;
- ⑦ With a good dynamic characteristics, easy arc, arc stability, easy to control the pool;
- ⑧ With precise preset welding current to make sure good welding result and energy saving more energy ,easy to operate and suitable for different thickness work-piece, thin plate in small current and thick plate in large current.

2) APPLICATION:

Suitable for welding of carbon steel, alloy steel, non-ferrous metals, suitable for boiler pressure-melt industrial power plants, aerospace manufacturing, industrial, automotive and vehicle manufacturing, construction and other related metals welding industry.

3) MODEL EXPLANATION:

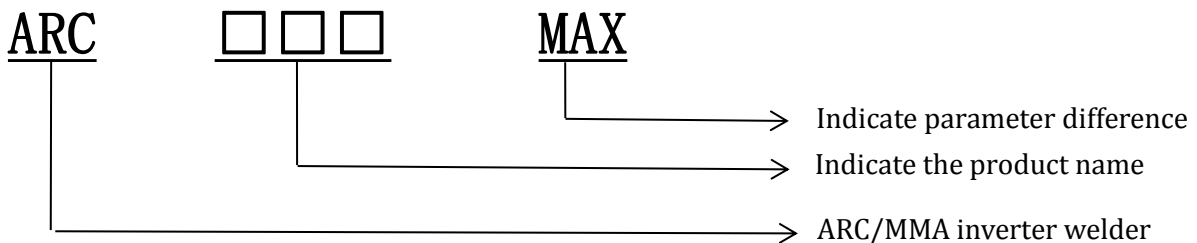

4) LABEL EXPLANATIONS:

	Read all safety regulations and instructions		Earthing loop
	Disconnct the machine from the mains before installation or adjustment		Attention.Warning of possible user health damage
	Wear a welding mask		Movement direction
	Wear a dust mask		Unlocked
	Rotation direction		Locked

Note: Be sure to identify the product model on the nameplate, the same product model may have different parameters.

2. TECHNICAL PARAMETERS TABLE

Model Parameters	ARC 160 MAX	ARC 200 MAX	ARC 250D MAX	ARC 250 MAX	ARC 300 MAX
Power voltage (V)	AC220 ±15%	AC220 ±15%	AC220 ±15%	AC380V ±15%	AC380V ±15%
Frequency (Hz)	50/60	50/60	50/60	50/60	50/60
Rated input current (A)	32	40	56	16	21
No-load voltage (V)	70	70	62	60	60
Output current (A)	30-170	30-210	30-240	30-260	30-300
Rated output voltage (V)	26.8	28.4	29.2	30.4	32
Hot Start(A)	1-100	1-100	1-100	1-100	1-100
Force adjusting range(A)	1-10	1-10	1-10	1-10	1-10
Duty cycle (%)	30	30	30	40	30
No-load loss (W)	40	40	40	80	80
Efficiency (%)	80	80	80	85	85
Power factor	0.73	0.73	0.73	0.93	0.93
Insulation grade	F	F	F	F	F
Housing protection grade	IP21	IP21	IP21	IP21	IP21
Weight (kg)	4.64	4.64	9.19	6.6	9.19
Dimensions (mm)	305*146*258	305*146*258	403*181*324	350*159*300	403*181*324

Model Parameters	ARC 160 MAX		ARC 200 MAX		ARC 250D MAX		ARC400 MAX
Power voltage (V)	AC220 ±15%	AC380 V±15%	AC220 ±15%	AC380 V±15%	AC220 ±15%	AC380 V±15%	AC380V ±15%
Frequency (Hz)	50/60		50/60		50/60		50/60
Rated input current (A)	32	15	40	21	45	23	23
No-load voltage (V)	77	68	77	68	77	68	60
Output current (A)	30-170		30-210		30-200	30-240	30-400
Rated output voltage (V)	26.4		28		28	29.6	36
Hot Start(A)	1-100		1-100		1-100		1-100
Force adjusting range(A)	1-10		1-10		1-10		1-10
Duty cycle (%)	30		30		30		30
No-load loss (W)	40		40		40		80
Efficiency (%)	80		80		80		85
Power factor	0.73		0.73		0.73		0.93
Insulation grade	F		F		F		F
Housing protection grade	IP21		IP21		IP21		IP21
Weight (kg)	4.64		4.64		6.6		12.51
Dimensions (mm)	305*146*258		305*146*258		350*159*300		458*219*353

3. PANEL FUNCTION INSTRUCTION

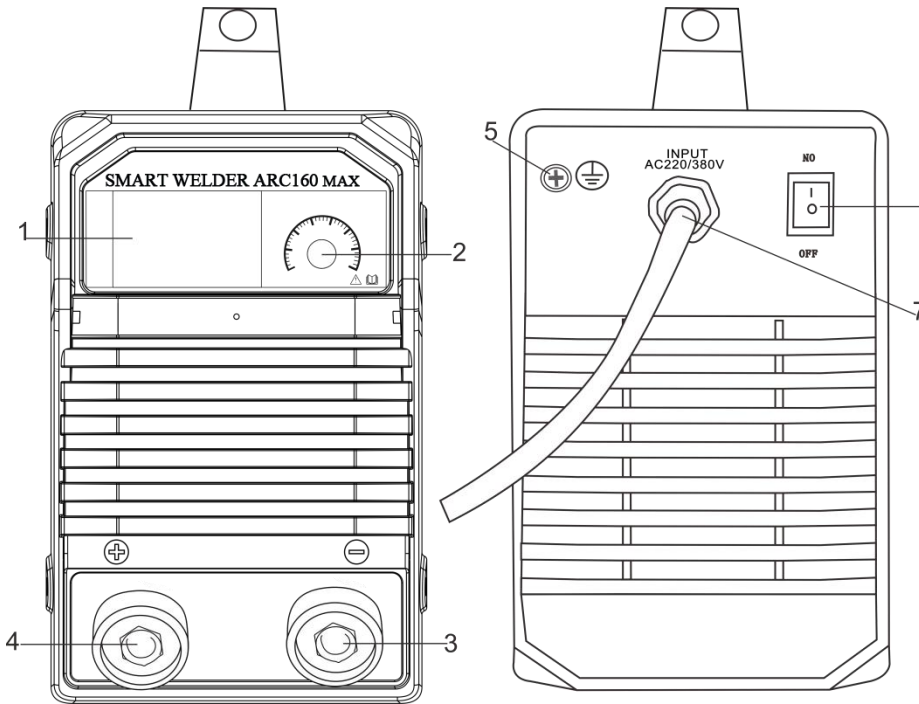

Function description:	
1	LED display
2	①current adjustment knob ②Press to switch functions
3	Positive output
4	Negative output
5	Grounding bolt
6	Power switch
7	Input power cable

Picture3-1 ARC160MAX/ARC200MAX/ARC250DMAX

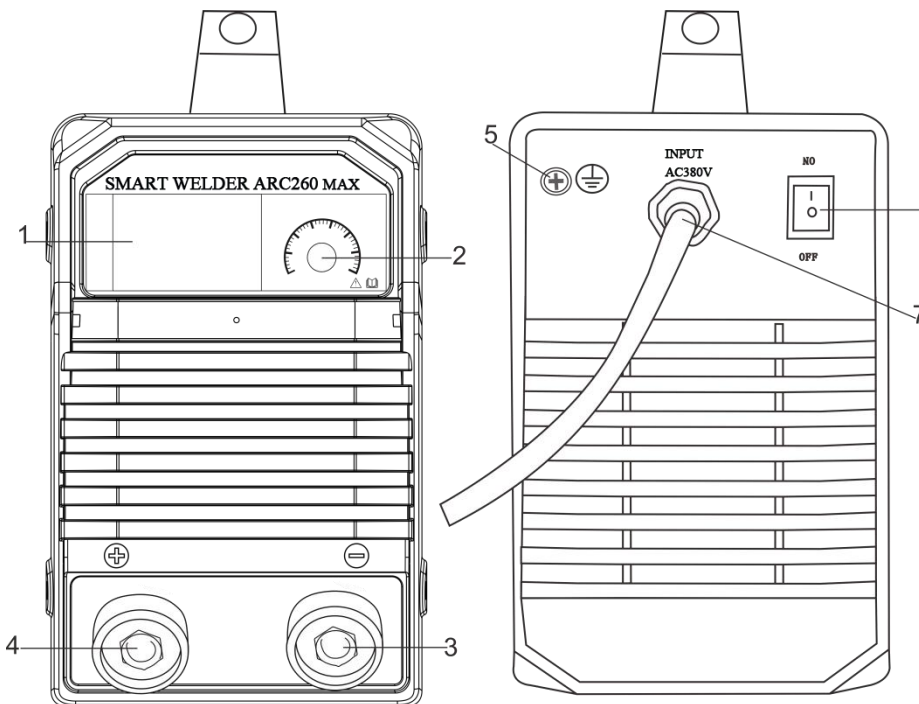

Function description:	
1	LED display
2	①current adjustment knob ②Press to switch functions
3	Positive output
4	Negative output
5	Grounding bolt
6	Power switch
7	Input power cable

Picture3-2 ARC250MAX/ARC315MAX

4. ACCESSORY DRAWING

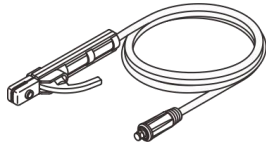

Picture 4-1 Electrode holder with cable

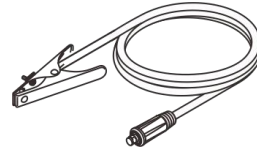

Picture 4-2 Earth clamp with cable

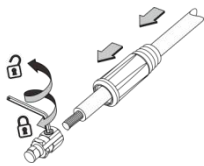

Picture 4-3 Connector assembly way



Picture 4-4 Internal hexagonal wrench

5. INSTALLATION INSTRUCTION

If the connecting cable is too long, it will have a great influence on the arcing performance as well as the stability of the welding performance. Therefore, please use the recommended length. If you want to reduce the voltage drop, please use a cable with a larger cross section.

1) Ground the cables with section area no less than 6mm^2 to the housing, the way is connecting screw in the back of the power source to ground device;

2) Connect the power cable to the distribution box with the corresponding voltage level of the welder. Do not connect the wrong voltage and ensure that the fluctuation of the input voltage is within the allowable range;

3) Make sure that the input power cable, output electrode holder, and output earth clamp are reliably connected. For the output interface, refer to the connection method below and tighten it clockwise;

4) Please pay attention to the connecting terminal, DC welding machine has two connecting ways: positive connection and negative connection. Positive connection: connect the electrode holder with “-” terminal, while workpiece with the “+” terminal. Negative connection: workpiece with the “-” terminal, holder with the “+” terminal. Choose suitable way according to the working situation. If unsuitable choice is made, it will cause unstable arc, more spatters and conglutination. If such problems occur, please change the polarity of the fastening plug.

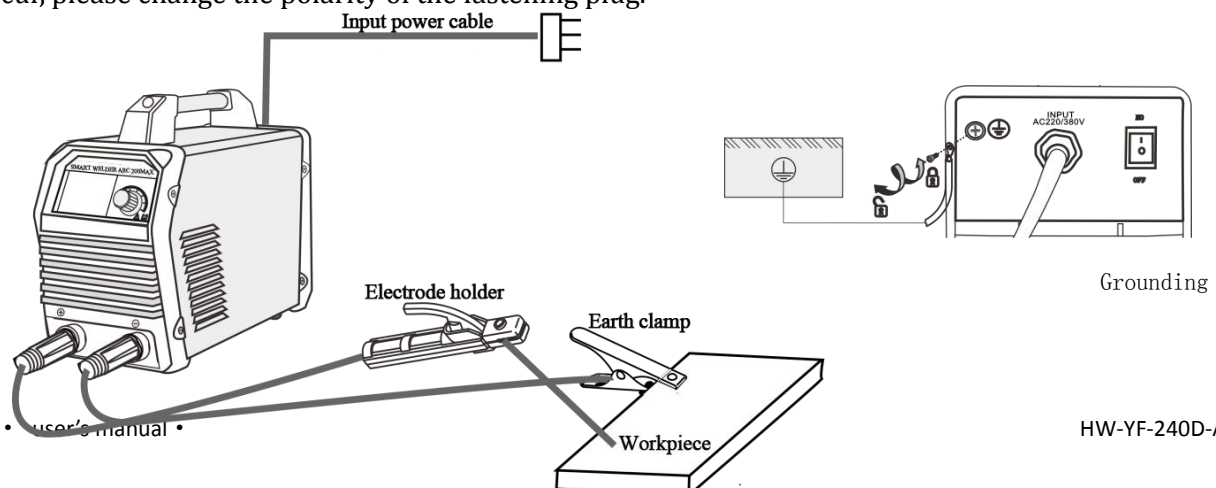

Picture5-1 Installation of ARC 200 MAX

6. OPERATION INSTRUCTION

- 1) Turn the power switch to “ON”,the power indicator lit up,cooling fan within the machine start to work immediately
- 2) Please ensure the suitable welding current and arc force current according to the thickness of the workpiece ,the diameter of the electrode, station and technology needs
- 3) Clip electrode to the electrode holder,the machine is in the manual welding mode and standby state.

Flat welding current and electrode specification list:

Specification	φ2.5	φ3.2	φ4.0	φ5.0
Current	70-100A	110-140A	170-220A	230-280A

- 4) Arc force adjusting function is used to adjust the welding performance, specially in vertical and overhead welding.With the use of welding current adjusting knob,it can achieve the ideal effect of welding.
- 5) When welding in wet, high altitude, narrow, metal containers and other places, it is recommended to use the VRD function which can ensure the no-load output voltage is about 14v-24v . (VRD indicator is on, VRD function is on)



WARNING!

Before connecting operation,please make sure all the power is turned off. The right order is to connect the electrode cable and earth clamp cable to the machine first, and make sure they are firmly connected and then put the power plug to the power source.

7. PRECAUTIONS

1) Environment

- ① The machine should be operated in dry environments with humidity level of max 90%.
- ② Ambient temperature should be between -10 to 40 degree centigrade.
- ③ Avoid welding in sunshine or drippings. Do not let water infiltrate the machine.
- ④ Avoid welding in dusty area or the environment with corrosive gas.

2) Safety norms

The welding machine is installed with protection circuit of over voltage, over current and over heat. When voltage, output current and temperature of machine exceed the required standard, welding machine will stop working automatically. However, overuse (such as over voltage) will still result in damage to the welding machine. To avoid this, the user must pay attention to the following notes.

- ① The working area is adequately ventilated!

The welding machine is powerful machine. When it is being operated, it generated by high current, under this situation, natural wind will not satisfy machine cool demands. So a fan is used into inner-machine to cool down itself. Make sure the intake is not blocked or covered. The objects around the welding machine should be kept away not less than 0.3 meters. Make sure the working area adequately ventilated is specially necessary. It is vitally important for the performance and longevity of the machine

- ② Do not over load!

The operator should remember to watch the max duty current (Response to the selected duty cycle). Keep welding current is not exceed max duty cycle current. Over-load current will damage and burn up machine.

- ③ Do not over voltage!

Power voltage can be found in diagram of main technical data. Automatic compensation circuit of voltage will assure the welding current keep in allowable range. If power voltage exceeds the allowable range limited, it will damage to components of machine. The operator should understand this situation and take preventive measures.

- ④ There is a grounding screw behind welding machine, with a grounding marker on it. Before operation, welding crust must be grounded reliable with cable which section is over 6 square millimeter, in order to prevent from static electricity, and accidents possibly caused by electricity leaking.

- ⑤ If welding time exceeds the duty cycle limited, welding machine will stop working for protection. Because machine is overheated, temperature control switch is on "ON" position and the indicator light is yellow (red). In this situation, you needn't pull the plug, in order to let the fan cool the

machine. When the indicator light is off, and the temperature goes down, it can weld again.

8. MAINTENANCE

1) Remove dust by dry and clean compressed air regularly, if welding machine is operating in environment where is polluted with smokes and pollution air, the machine need remove dust every month.

2) Pressure of compressed air must be within the reasonable range in order to prevent damaging to small components of inner-machine.

3) Check internal circuit of welding machine regularly and make sure the circuit connections are connected correctly and tightly (especially plug-in connector and components). If scale and rust are found, please clean it, and connect again tightly.

4) Prevent water and steam from entering into the machine. If that happens, please blow it dry and check insulation of machine.

5) If welding machine will not be used for long time, it must be put into the packing box and stored in dry and clean environment.

9. TROUBLESHOOTING AND FAULT FINDING

1) ARC160MAX /ARC200MAX /ARC250DMAX fault symptom and remedy

Fault symptom	Remedy
No display on meter, fan does not work, no welding output.	<ol style="list-style-type: none"> 1. Make sure power switch is on. 2. Confirm the power input cable receive electricity.
Normal meter display,,normal welding output ,fan does not work	<ol style="list-style-type: none"> 1. Check whether the fan is damaged. 2. Check whether the fan power supply socket is voltage output.
No display on meter,fan works,no welding output,abnormal indicator does not lit.	<ol style="list-style-type: none"> 1. Check whether digital display is damaged,if there is a loose, break cables. 2. Control circuit problem, please contact the distributor or the company.
Normal meter display,power indicator is lit, Fan is working and abnormal indicator is lit, no welding output.	<ol style="list-style-type: none"> 1. May be over-current protection, turn off the machine until the abnormal light is off, then reboot. 2. May be overheating protection, wait for 5 to 10 minutes, the machine can recover automatically. 3. May be the feedback circuit or control board malfunction, please contact the distributor or the company.
Power on trip, power switch cannot be closed	<ol style="list-style-type: none"> 1. Maybe there is a problem with the power switch itself. 2. Check for a short inside the machine. 3. Check whether the silicon bridge is damaged

2) ARC250MAX/ ARC315MAX fault symptom and remedy

Fault symptom	Remedy
No display on meter, fan does not work, no welding output.	<ol style="list-style-type: none"> 1. Make sure power switch is on. 2. Confirm the power input cable receive electricity. 3. Whether the power supply is lack of phase
Normal meter display, power indicator is lit, Fan is working and abnormal indicator is lit, no welding output.	<ol style="list-style-type: none"> 1. May be over-current protection, turn off the machine until the abnormal light is off, then reboot. 2. May be overheating protection, wait for 5 to 10 minutes, the machine can recover automatically. 3. May be the feedback circuit or control board malfunction, please contact the distributor or the company.
Normal meter display, normal welding output, fan does not work	<ol style="list-style-type: none"> 1. Check whether the fan is damaged. 2. Check whether the fan power supply socket is voltage output.
Power on trip, power switch cannot be closed	<ol style="list-style-type: none"> 1. Maybe there is a problem with the power switch itself. 2. Check for a short inside the machine. 3. Check whether the silicon bridge is damaged
Big spatter during welding	<ol style="list-style-type: none"> 1. The current setting does not match the diameter of the electrode used. 2. The output polarity connection is not reasonable, just adjust the output line polarity.

If the machine still not work after the calibration and maintenance, please contact the local distributor or our after-sales service department.



Notes: The above operations must be carried out by qualified electricians with valid certification. Please contact us before repair to obtain professional advice.

INVERTER MMA/ARC SMART WELDER MAX SERIES

